

Designed for plastics, rubber and elastomer testing, these extensometers have very long measuring ranges. Their unique design allows testing to failure and minimizes interaction with the sample.

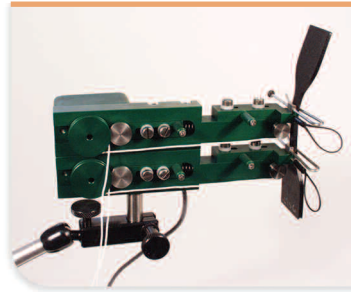

Model 3800 with mounting stand

The main body of this unique extensometer remains stationary during testing, held in position by the adjustable magnetic base included. Only the very light, small traveling heads move as the sample elongates during a test. These attach to the sample with small spring clips. Each head pulls a cord out from the extensometer as the head moves.

These models use high precision, low friction potentiometers, and, as a result, have a wide range of factory selectable outputs. The extensometer is driven by an excitation voltage and has output proportional to the input. They can be provided with high level outputs (approximately 2-8 VDC) or ones that mimic strain gaged devices (2-4 mV/V). When set to mimic strain gaged extensometers, the Model 3800 can be used with virtually any signal conditioning electronics designed for strain gaged sensors. The potentiometers employ a hybrid wire wound around conductive plastic, which provides excellent long term stability. The output from the extensometer is readily interfaced with most existing test controllers, and may be directly input to data acquisition systems and chart recorders.

Please let us know at the time of order what type of output and connector you require.



Specimen attachment with Model 3800

**Features**

- May be left on through specimen failure. The main body is stationary with only the lightweight traveling heads moving.
- Includes high quality foam lined case.
- Comes with an adjustable magnetic base for easy mounting.
- Large measuring range to 20 inches (500 mm).
- Low cost, high accuracy elastomer strain measurement.

**SPECIFICATIONS**

- Excitation:* 5 to 10 VDC recommended, 12 VDC or VAC max.
- Output:* Either 2 to 8 VDC, depending on model (at 10 VDC input) or 2 to 4 mV/V, nominal, selectable at time of order
- Linearity:* ≤0.15% of full scale measuring range
- Resolution:* 0.18 mm for all measuring ranges
- Temperature Range:* -40 °C to 100 °C (-40 °F to 210 °F)
- Cable:* Integral, ultra-flexible cable, 8 ft (2.5 m) standard
- Operating Force:* 20 grams typical, each head

**OPTIONS**

- Can be provided with either:
- High level outputs (approximately 2-8 VDC)
  - Or output that mimics strain gaged devices (2-4 mV/V nominal) 2 mV/V output for use with electronics designed for strain gaged sensors
- Shunt calibration module is available for units configured to mimic strain gaged sensors (see page 104)



**ORDERING INFORMATION**

**Model 3800 Available Versions:** ANY combination of measuring ranges and gauge length listed below is available. Available in intermediate and larger gauge lengths on special order.

Gauge Length		Measuring Range	
U.S.A.	-0100 -0200	1.000" 2.000"	
METRIC	-020M -025M -050M	20.0 mm 25.0 mm 50.0 mm	
U.S.A.	-050T -100T -200T		+5.000" +10.000" +20.000"
METRIC	-125M -250M -500M		+125 mm +250 mm +500 mm

Model Number 3800- \_\_\_\_\_ - \_\_\_\_\_

**Example:** 3800-0100-100T: 1.0 inch gauge length, +10 inches measuring range (+1000% strain), temperature range of -40 °F to 210 °F

Visit our website at [www.epsilontech.com](http://www.epsilontech.com)  
Contact us for your special testing requirements.

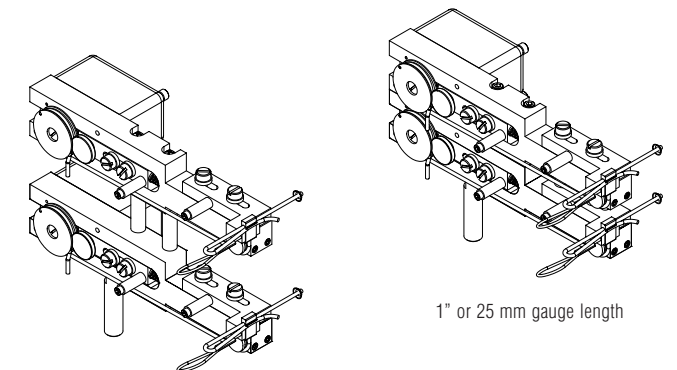

2" or 50 mm gauge length

1" or 25 mm gauge length

MODEL 3800 EXAMPLES

Visit our website at [www.epsilontech.com](http://www.epsilontech.com)

