

Data Sheet

R-Series V RDV Analog

Magnetostrictive Linear Position Sensors

- Space-saving installation due to detached sensor electronics housing
- Backwards compatible with RD4 generation
- All advantages of the R-Series V

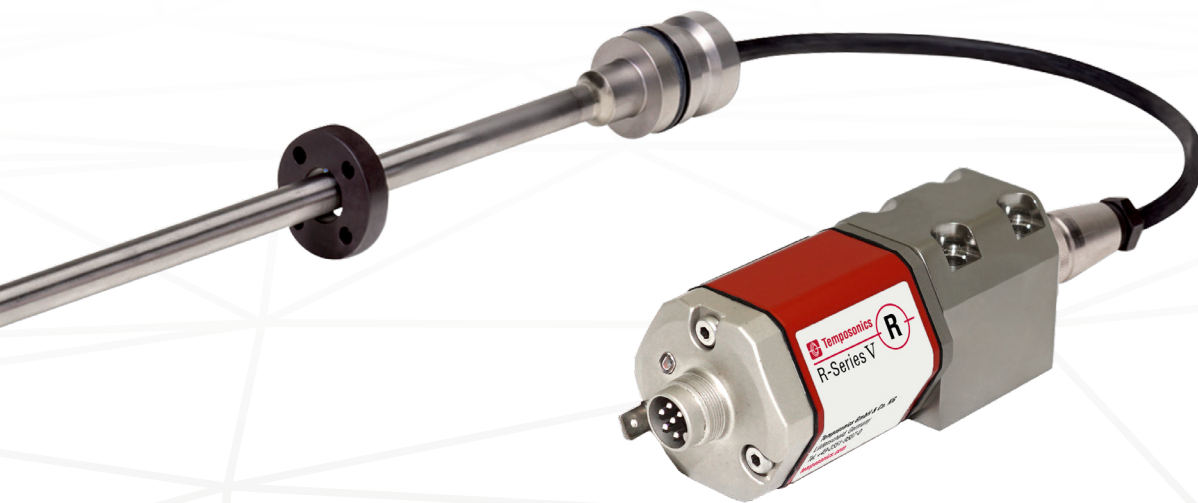

V
THE NEW GENERATION

MEASURING TECHNOLOGY

The absolute, linear position sensors provided by Temposonics rely on the company's proprietary magnetostrictive technology, which can determine position with a high level of precision and robustness. Each Temposonics position sensor consists of a ferromagnetic waveguide, a position magnet, a strain pulse converter and a supporting electronics. The magnet, connected to the object in motion in the application, generates a magnetic field at its location on the waveguide. A short current pulse is applied to the waveguide. This creates a momentary radial magnetic field and torsional strain on the waveguide. The momentary interaction of the magnetic fields releases a torsional strain pulse that propagates the length of the waveguide. When the ultrasonic wave reaches the beginning of the waveguide it is converted into an electrical signal. Since the speed of the ultrasonic wave in the waveguide is precisely known, the time required to receive the return signal can be converted into a linear position measurement with both high accuracy and repeatability.

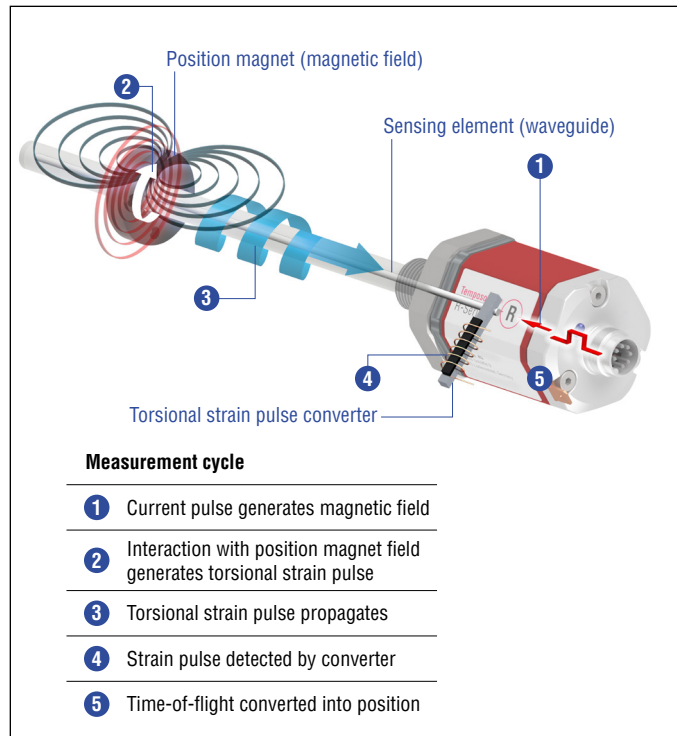
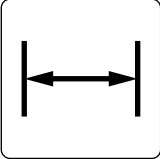
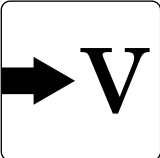



Fig. 1: Time-of-flight based magnetostrictive position sensing principle

R-SERIES V RDV Analog

The Temposonics® R-Series V brings very powerful sensor performance to meet the many demands of your application. The sensor RDV is the version of the R-Series V with a detached sensor electronics. The main advantages of the version RDV are:

- 

Space-saving installation
The detached sensor electronics allow space-saving installation of the compact measuring rod.
- 

R-Series V platform
The detached sensor electronics is based on the R-Series V and offers all advantages of the innovative series.
- 

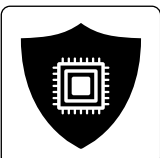
Backwards compatible
Mechanically and electrically, the sensors are backwards compatible with the RD4. This means that the sensor rod or the sensor electronics can be replaced without any problems.
- 

Protection of the sensor electronics
By separating the robust sensor rod from the complex evaluation electronics, improved protection against process influences can be realized.

In addition the R-Series V Analog scores with the following features:

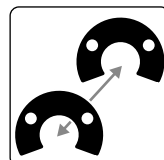

2 positions simultaneously

The R-Series V Analog can detect and report the position of up to 2 magnets simultaneously.

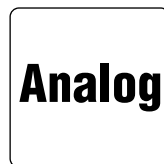

R-Series V Analog

With the R-Series V Analog you can configure the Analog output (current/voltage) that it fits best for your application and also adjust it on site with the sensor assistant.

All settings under control with the sensor assistant for the R-Series V
The TempoLink® smart assistant supports you in setup and diagnostics of the R-Series V.

For more information of the assistant please see the data sheet:

- TempoLink® smart assistant
([Document part number: 552070](#))



TECHNICAL DATA

Output							
Analog	Voltage: 0...10/10...0/-10...+10/+10...-10 VDC (min. controller load > 5 kΩ) Current: 4(0)...20/20...4(0) mA (min./max. load 0/500 Ω)						
Measured output variables	Position for one or two position magnets Position + speed (without direction) or velocity (with direction) for one position magnet Position for one position magnet + temperature inside the sensor electronics housing						
Measurement parameters							
Position measurement							
Null/Span adjustment	100 % of electrical stroke						
Resolution	16 bit (internal resolution 0.1 μm)						
Update time	Stroke length	≤ 200 mm	≤ 350 mm	≤ 1200 mm	≤ 2400 mm	≤ 4800 mm	≤ 5080 mm
	Update time	0.25 ms	0.333 ms	0.5 ms	1.0 ms	2.0 ms	2.2 ms
Linearity deviation ^{1,2}	Stroke length	≤ 500 mm	> 500 mm				
	Linearity deviation	≤ ±50 μm	< ±0.01 % F.S.				
Repeatability	< ±0.001 % F.S. (minimum ±1 μm)						
Hysteresis	< 4 μm typical						
Temperature coefficient	< 30 ppm/K typical						
Velocity measurement							
Range	0.01...10 m/s or 1...400 in./s						
Deviation	≤ 0.05 %						
Resolution	16 bit (minimum 0.01 mm/s)						
Operating conditions							
Operating temperature	-40...+85 °C (-40...+185 °F)						
Humidity	90 % relative humidity, no condensation						
Ingress protection	Sensor electronics IP67 (with professional mounted housing and connectors) Measuring rod with connecting cable for side cable entry IP65 Measuring rod with single wires and flat connector with bottom cable entry IP30						
Shock test	100 g/11 ms, IEC standard 60068-2-27						
Vibration test	10 g/10...2000 Hz, IEC standard 60068-2-6 (excluding resonant frequencies)						
EMC test	Electromagnetic emission according to EN 61000-6-3						
	Electromagnetic immunity according to EN 61000-6-2 The RDV sensors fulfill the requirements of the EMC directives 2014/30/EU, UKSI 2016 No. 1091 and TR CU 020/2011 under the condition of an EMC compliant installation ³						
Operating pressure	350 bar (5076 psi)/700 bar (10,153 psi) peak (at 10 × 1 min) for sensor rod						
Magnet movement velocity	Any						
Design/Material							
Sensor electronics housing	Aluminum (painted), zinc die cast						
Sensor rod with flange	Stainless steel 1.4301 (AISI 304)						
RoHS compliance	The used materials are compliant with the requirements of EU Directive 2011/65/EU and EU Regulation 2015/863 as well as UKSI 2022 No. 622						
Stroke length	25...2540 mm (1...100 in.) for pressure-fit flange »S«						
	25...5080 mm (1...200 in.) for all threaded flanges						

Technical data “Mechanical mounting” and “Electrical connection” on [page 4](#)

1/ With position magnet # 251 416-2

2/ For rod style »S« the linearity deviation can be higher in the first 30 mm (1.2 in.) of stroke length

3/ The cable between the sensor element and the sensor electronics housing must be mounted in an appropriately shielded environment

Temposonics® R-Series V RDV Analog

Data Sheet

Mechanical mounting	
Mounting position	Any
Mounting instruction	Please consult the technical drawings on page 5 , page 6 and page 7 and the operation manual (document part number: 552063)
Electrical connection	
Connection type	1 × M16 male connector (6 pin), 1 × M12 male connector (5 pin) or cable outlet
Operating voltage	12...30 VDC ±20 % (9.6...36 VDC)
Power consumption	< 3.25 W
Dielectric strength	500 VDC (DC ground to machine ground)
Polarity protection	Up to -36 VDC
Overvoltage protection	Up to 36 VDC



TECHNICAL DRAWING

RDV with bottom cable entry, example: Connection type EXX/GXX/LXX (angled cable outlet)

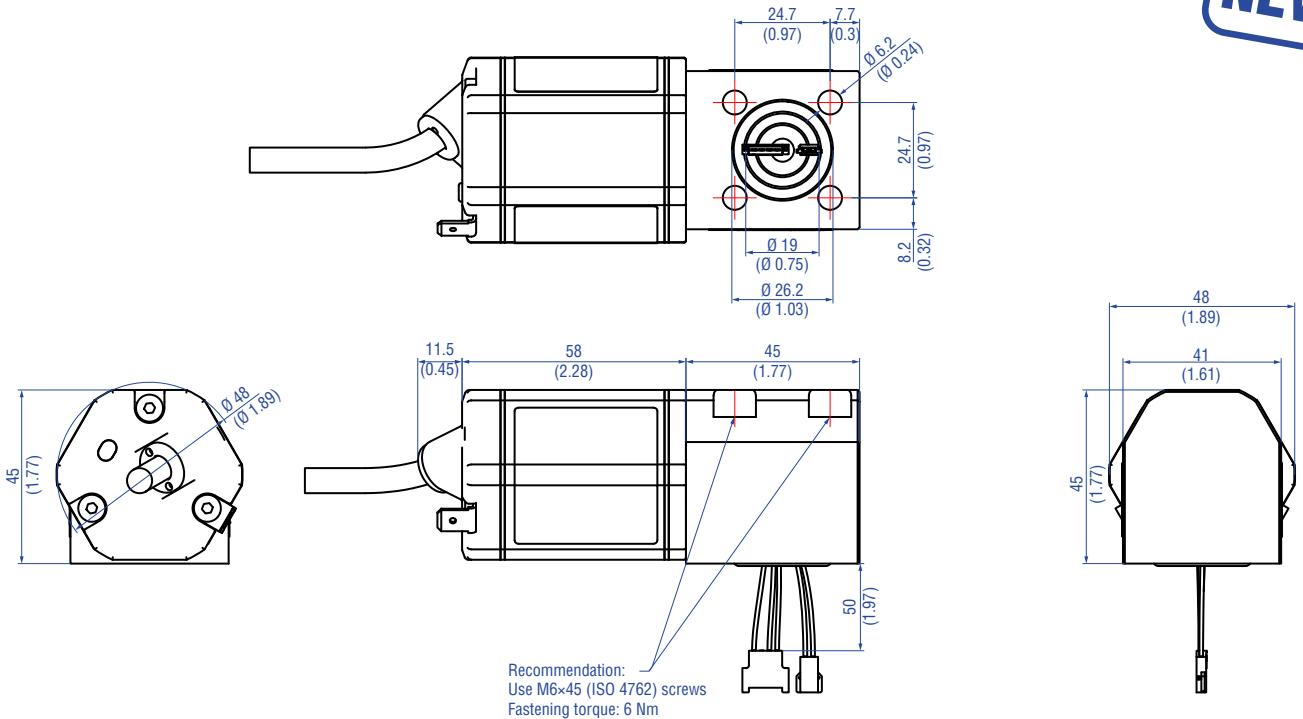

RDV with side cable entry, example: Connection type D60 (connector outlet)

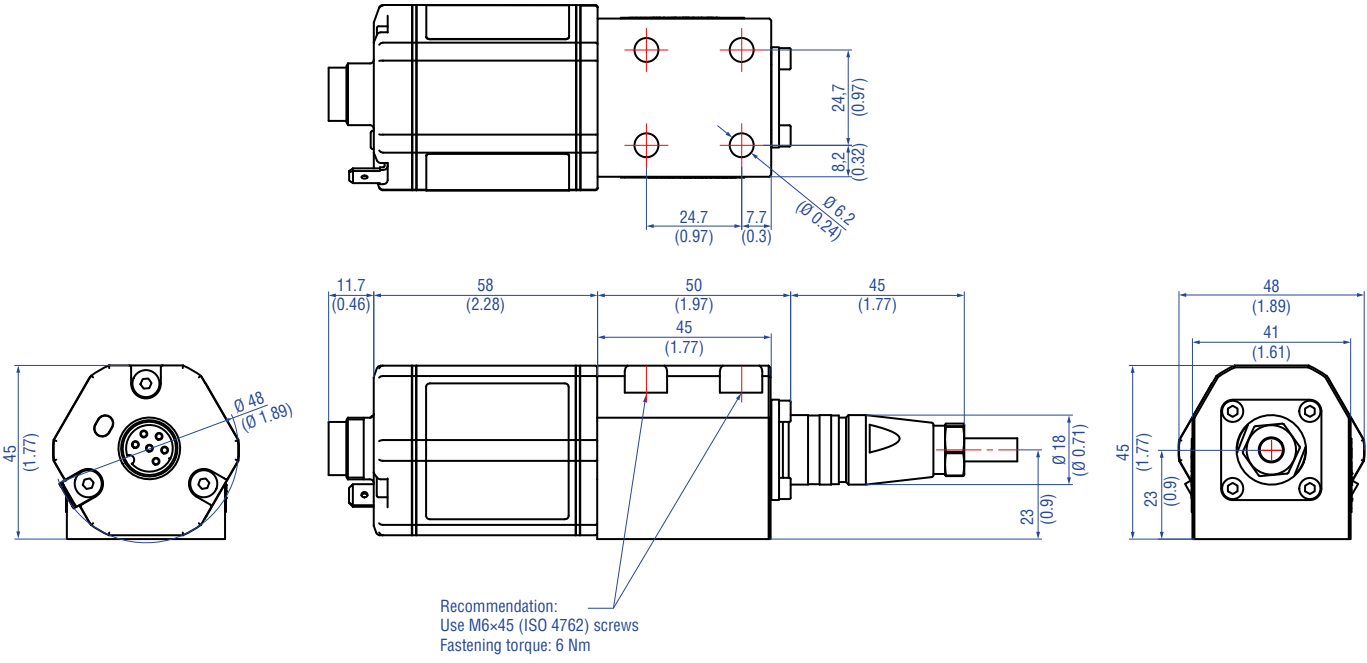

Controlling design dimensions are in millimeters and measurements in () are in inches

Fig. 2: Temposonics® RDV sensor electronics housing, part 1

RDV with side cable entry, example: Connection type D34 (connector outlet)

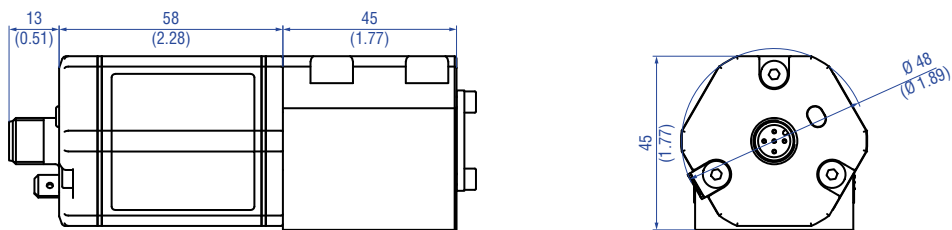

RDV with bottom cable entry, example: Connection type HXX/RXX (straight cable outlet)

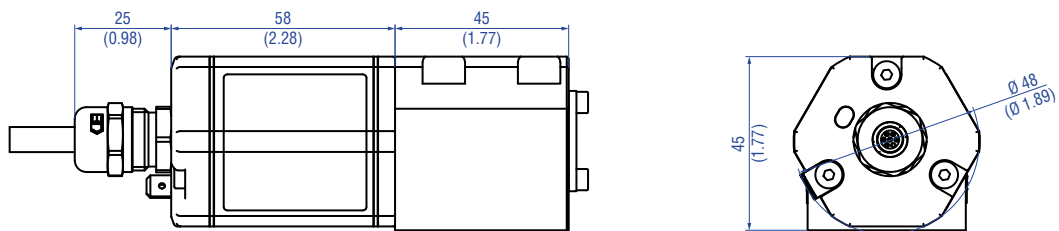

RDV with side cable entry, example: Connection type TXX (straight cable outlet)

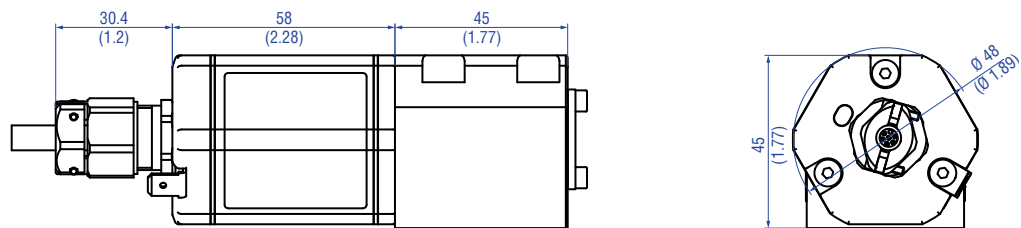

Controlling design dimensions are in millimeters and measurements in () are in inches

Fig. 3: Temposonics® RDV sensor electronics housing, part 2

Threaded flange »C« & »D« (for bottom or side cable entry)

PUR cable:
Ø 6 (Ø 0.24)
Bending radius:
> 24 (> 0.94)
Cable length (bottom cable entry):
65/170/230/350
(2.6/6.7/9.1/13.8)
Cable length (side cable entry):
250/400/600
(9.8/15.7/23.6)

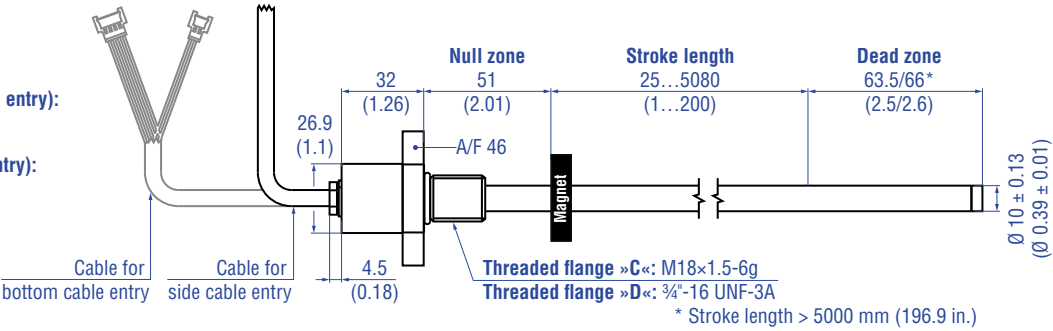

Threaded flange »M« (for bottom or side cable entry)

PUR cable:
Ø 6 (Ø 0.24)
Bending radius:
> 24 (> 0.94)
Cable length (bottom cable entry):
65/170/230/350
(2.6/6.7/9.1/13.8)
Cable length (side cable entry):
250/400/600
(9.8/15.7/23.6)

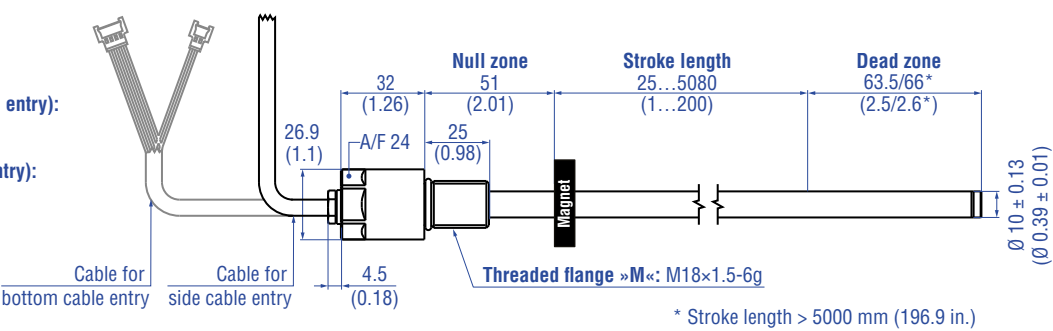

Threaded flange »T« (for bottom or side cable entry)

PUR cable:
Ø 6 (Ø 0.24)
Bending radius:
> 24 (> 0.94)
Cable length (bottom cable entry):
65/170/230/350
(2.6/6.7/9.1/13.8)
Cable length (side cable entry):
250/400/600
(9.8/15.7/23.6)

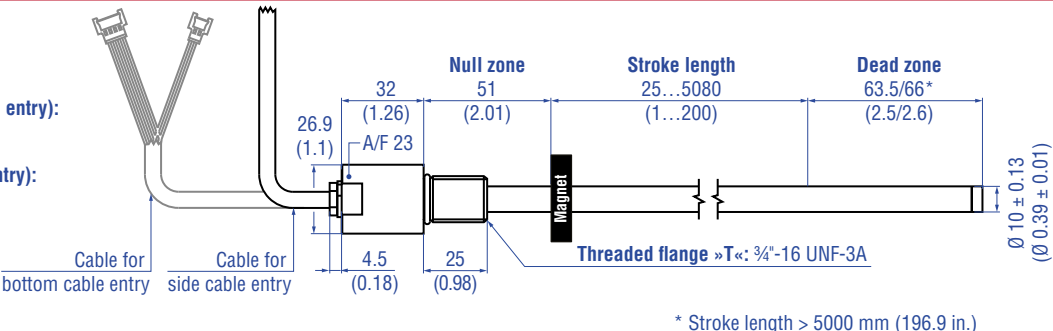

Pressure fit flange »S« (for bottom or side cable entry)

PUR cable:
Ø 6 (Ø 0.24)
Bending radius:
> 24 (> 0.94)
Cable length (bottom cable entry):
65/170/230/350
(2.6/6.7/9.1/13.8)
Cable length (side cable entry):
250/400/600
(9.8/15.7/23.6)

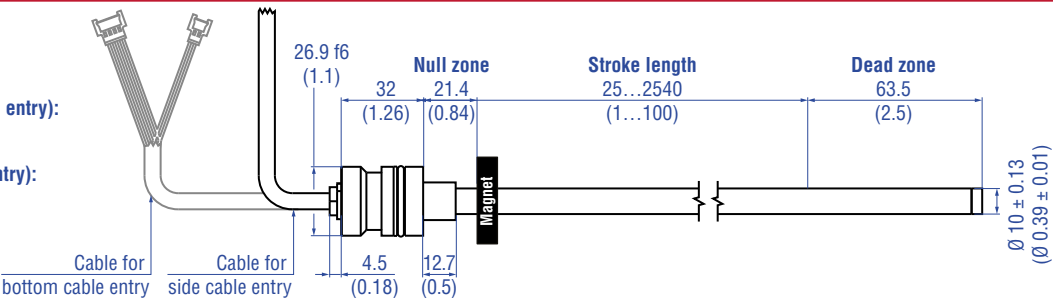

Controlling design dimensions are in millimeters and measurements in () are in inches

Fig. 4: Temposonics® RDV flange types

CONNECTOR WIRING

D34			
Signal + power supply			
M12 male connector	Output	Pin	Function
 <p>View on sensor</p>	1	1	+12...30 VDC (±20 %)
		2	Position (magnet 1)
		3	DC Ground (0 V)
	2*	4	Position (magnet 2) or reverse position (magnet 1) or speed or velocity (magnet 1) or temperature inside the sensor electronics housing
		5	Signal Ground

* order dependent

Fig. 5: Connector wiring D34

D60			
Signal + power supply			
M16 male connector	Output	Pin	Function
 <p>View on sensor</p>	1	1	Position (magnet 1)
		2	Signal Ground
	2*	3	Position (magnet 2) or reverse position (magnet 1) or speed or velocity (magnet 1) or temperature inside the sensor electronics housing
		4	Signal Ground
		5	+12...30 VDC (±20 %)
		6	DC Ground (0 V)

* order dependent

Fig. 6: Connector wiring D60

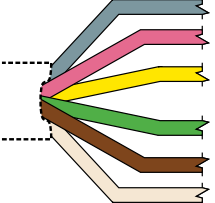
HXX or LXX / RXX or EXX / TXX or GXX / UXX			
Signal + power supply			
Cable	Output	Color	Function
	1	GY	Position (magnet 1)
		PK	Signal Ground
	2*	YE	Position (magnet 2) or reverse position (magnet 1) or speed or velocity (magnet 1) or temperature inside the sensor electronics housing
		GN	Signal Ground
		BN	+12...30 VDC (±20 %)
		WH	DC Ground (0 V)

* order dependent

For cable type TXX, the extra red & blue wires are not used.

Fig. 7: Connector wiring cable outlet

Straight cable outlet			Cable type	Angled cable outlet
H	X	X	Part no. 530 052 PUR	→ L X X Part no. 530 052
R	X	X	Part no. 530 032 PVC	→ E X X Part no. 530 032
T	X	X	Part no. 530 112 FEP	→ G X X Part no. 530 157

Fig. 8: Cable types assignment

FREQUENTLY ORDERED ACCESSORIES – Additional options available in our [Accessories Catalog](#) 551444

Position magnets			
<p>U-magnet OD33 Part no. 251 416-2</p>	<p>Ring magnet OD33 Part no. 201 542-2</p>	<p>Ring magnet OD25.4 Part no. 400 533</p>	<p>Ring magnet OD17.4 Part no. 401 032</p>
<p>Material: PA ferrite GF20 Weight: Approx. 11 g Surface pressure: Max. 40 N/mm² Fastening torque for M4 screws: 1 Nm Operating temperature: -40...+105 °C (-40...+221 °F)</p>	<p>Material: PA ferrite GF20 Weight: Approx. 14 g Surface pressure: Max. 40 N/mm² Fastening torque for M4 screws: 1 Nm Operating temperature: -40...+105 °C (-40...+221 °F)</p>	<p>Material: PA ferrite Weight: Approx. 10 g Surface pressure: Max. 40 N/mm² Operating temperature: -40...+105 °C (-40...+221 °F)</p>	<p>Material: PA neobond Weight: Approx. 5 g Surface pressure: Max. 20 N/mm² Operating temperature: -40...+105 °C (-40...+221 °F)</p>
Magnet spacer		O-rings	
<p>Magnet spacer Part no. 400 633</p>	<p>O-ring for threaded flange M18x1.5-6g Part no. 401 133</p>	<p>O-ring for threaded flange 3/4"-16 UNF-3A Part no. 560 315</p>	<p>O-ring for pressure fit flange Ø 26.9 mm Part no. 560 705</p>
<p>Material: Aluminum Weight: Approx. 5 g Surface pressure: Max. 20 N/mm² Fastening torque for M4 screws: 1 Nm</p>	<p>Material: Fluoroelastomer Durometer: 75 ± 5 Shore A Operating temperature: -40...+204 °C (-40...+400 °F)</p>	<p>Material: Fluoroelastomer Durometer: 75 ± 5 Shore A Operating temperature: -40...+204 °C (-40...+400 °F)</p>	<p>Material: Nitrile rubber Operating temperature: -53...+107 °C (-65...+225 °F)</p>
O-rings		Mounting accessories	
<p>Back-up ring for pressure fit flange Ø 26.9 mm Part no. 560 629</p>	<p>O-ring for mounting block with bottom entry Part no. 561 435</p>	<p>Hex jam nut M18x1.5-6g Part no. 500 018</p>	<p>Hex jam nut 3/4"-16 UNF-3A Part no. 500 015</p>
<p>Material: Polymyte Durometer: 90 Shore A</p>	<p>Material: FKM Durometer: 80 ± 5 Shore A Operating temperature: -15...+200 °C (5...+392 °F)</p>	<p>Material: Steel, zinc plated</p>	<p>Material: Steel, zinc plated</p>

Controlling design dimensions are in millimeters and measurements in () are in inches

Mounting accessory

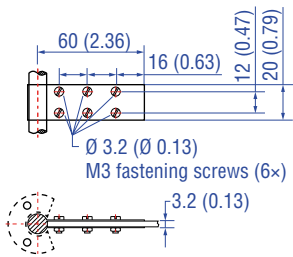



Fixing clip
Part no. 561 481

Application: Used to secure sensor rods ($\varnothing 10$ mm ($\varnothing 0.39$ in.)) when using an U-magnet or block magnet
Material: Brass, non-magnetic

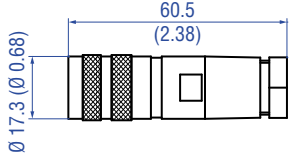
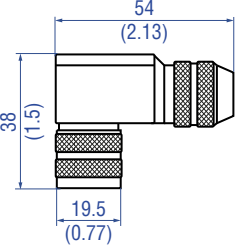
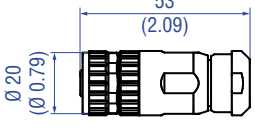
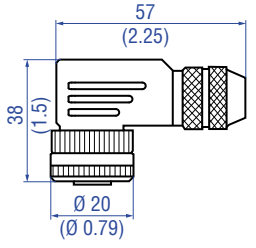
Cable connectors*

			
<p>M16 female connector (6 pin), straight Part no. 370 423</p>	<p>M16 female connector (6 pin), angled Part no. 370 460</p>	<p>M12 A-coded female connector (4 pin/5 pin), straight Part no. 370 677</p>	<p>M12 A-coded female connector (5 pin), angled Part no. 370 678</p>
<p>Material: Zinc nickel plated Termination: Solder Cable Ø: 6...8 mm (0.24...0.31 in.) Operating temperature: -40...+100 °C (-40...+212 °F) Ingress protection: IP65/IP67 (correctly fitted) Fastening torque: 0.6 Nm</p>	<p>Material: Zinc nickel plated Termination: Solder Cable Ø: 6...8 mm (0.24...0.31 in.) Wire: 0.75 mm² (20 AWG) Operating temperature: -40...+95 °C (-40...+203 °F) Ingress protection: IP67 (correctly fitted) Fastening torque: 0.6 Nm</p>	<p>Material: GD-Zn, Ni Termination: Screw Contact insert: CuZn Cable Ø: 4...8 mm (0.16...0.31 in.) Wire: 1.5 mm² Operating temperature: -30...+85 °C (-22...+185 °F) Ingress protection: IP67 (correctly fitted) Fastening torque: 0.6 Nm</p>	<p>Material: GD-Zn, Ni Termination: Screw; max. 0.75 mm² Contact insert: CuZn Cable Ø: 5...8 mm (0.2...0.31 in.) Wire: 0.75 mm² (18 AWG) Operating temperature: -25...+85 °C (-13...+185 °F) Ingress protection: IP67 (correctly fitted) Fastening torque: 0.4 Nm</p>

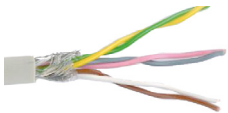
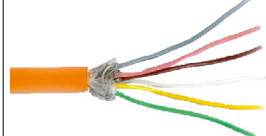
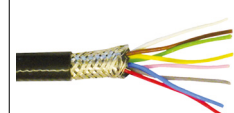
Cables

			
<p>PVC cable Part no. 530 032</p>	<p>PUR cable Part no. 530 052</p>	<p>FEP cable Part no. 530 112</p>	<p>FEP cable Part no. 530 157</p>
<p>Material: PVC jacket; gray Features: Twisted pair, shielded, flexible Cable Ø: 6 mm (0.23 in.) Cross section: 3 × 2 × 0.14 mm² Bending radius: 10 × D (fixed installation) Operating temperature: -40...+105 °C (-40...+221 °F)</p>	<p>Material: PUR jacket; orange Features: Twisted pair, shielded, highly flexible, halogen free, suitable for drag chains, mostly oil & flame resistant Cable Ø: 6.4 mm (0.25 in.) Cross section: 3 × 2 × 0.25 mm² Bending radius: 5 × D (fixed installation) Operating temperature: -30...+80 °C (-22...+176 °F)</p>	<p>Material: FEP jacket; black Features: Twisted pair, shielded, flexible, high thermal resistance, mostly oil & acid resistant Cable Ø: 7.6 mm (0.3 in.) Cross section: 4 × 2 × 0.25 mm² Bending radius: 8 – 10 × D (fixed installation) Operating temperature: -100...+180 °C (-148...+356 °F)</p>	<p>Material: FEP jacket; black Features: Twisted pair, shielded Cable Ø: 6.7 mm (0.26 in.) Cross section: 3 × 2 × 0.14 mm² Operating temperature: -100...+180 °C (-148...+356 °F)</p>

*/ Follow the manufacturer's mounting instructions
Controlling design dimensions are in millimeters and measurements in () are in inches

Cables **Cable sets**

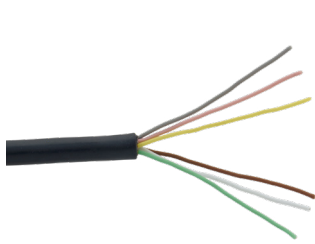

Silicone cable
Part no. 530 176

Material: Silicone jacket; black
Features: Twisted pair, shielded
Cable Ø: 6.3 mm (0.25 in.)
Cross section: 3 × 2 × 0.14 mm²
Bending radius: 7 × D
(fixed installation)
Operating temperature: -50...+150 °C
(-58...+302 °F)



Cable with M12 A-coded female connector (5 pin), straight – pigtail
Part no. 370 673

Material: PUR jacket; black
Features: Shielded
Cable length: 5 m (16.4 ft)
Ingress protection: IP67 (correctly fitted)
Operating temperature:
-25...+80 °C (-13...+176 °F)



Cable with M12 A-coded female connector (5 pin), angled – pigtail
Part no. 370 675

Material: PUR jacket; black
Features: Shielded
Cable length: 5 m (16.4 ft)
Ingress protection: IP67 (correctly fitted)
Operating temperature:
-25...+80 °C (-13...+176 °F)

Programming tools



Hand programmer for analog output
Part no. 253 124

Easy teach-in-setups of stroke length and direction on desired zero /span positions. For sensors with 1 magnet.



Cabinet programmer for analog output
Part no. 253 408

Features snap-in mounting on standard DIN rail (35 mm). This programmer can be permanently mounted in a control cabinet and includes a program/run switch. For sensors with 1 magnet.



TempoLink® kit for Temposonics® R-Series ∇
Part no. TL-1-0-AD60 (for D60)
Part no. TL-1-0-AS00 (for cable outlet)
Part no. TL-1-0-AD34 (for D34)

- Connect wirelessly via Wi-Fi enabled device or via USB with the diagnostic tool
- Simple connectivity to the sensor via 24 VDC power line (permissible cable length: 30 m)
- User friendly interface for mobile devices and desktop computers
- See data sheet “TempoLink® smart assistant” (document part no.: [552070](#)) for further information

Controlling design dimensions are in millimeters and measurements in () are in inches
Color of connectors and cable jacket may change. Colors of the cores and technical properties remain unchanged.

Extension cables



PVC cable with M16 female connector (6 pin), straight – pigtail

PVC cable (part no. 530 032) with M16 female connector, straight (part no. 370 423)

Order code:
K2-A-370423-xxxxyy-530032-0
(where xxxx = cable length and yy = unit in centimeters „CM“ or feet „FT“)



PUR cable with M16 female connector (6 pin), straight – pigtail

PUR cable (part no. 530 052) with M16 female connector, straight (part no. 370 423)

Order code:
K2-A-370423-xxxxyy-530052-0
(where xxxx = cable length and yy = unit in centimeters „CM“ or feet „FT“)



Teflon® cable with M16 female connector (6 pin), straight – pigtail

FEP cable (part no. 530 112) with M16 female connector, straight (part no. 370 423)

Order code:
K2-A-370423-xxxxyy-530112-0
(where xxxx = cable length and yy = unit in centimeters „CM“ or feet „FT“)

ORDER CODE

1	2	3	4	5	6	7	8	9	10	11	12	13	14	15	16	17	18	19	20	21	22	23	
R	D	V													1								
a			b		c		d				e		f			g	h	i	j	k	l		
optional																							

a	Design
R D V	Detached sensor electronics "Classic"

b	Design
C	Threaded flange M18×1.5-6g (A/F 46)
D	Threaded flange ¾"-16 UNF-3A (A/F 46)
M	Threaded flange M18×1.5-6g (A/F 24)
S	Pressure fit flange Ø 26.9 mm f6
T	Threaded flange ¾"-16 UNF-3A (A/F 23)

c	Mechanical options
For side cable entry	
A	PUR cable with M16 connector, 250 mm length
B	PUR cable with M16 connector, 400 mm length
C	PUR cable with M16 connector, 600 mm length
For bottom cable entry	
2	Single wires with flat connector, 65 mm length
4	Single wires with flat connector, 170 mm length
5	Single wires with flat connector, 230 mm length
6	Single wires with flat connector, 350 mm length

d	Stroke length
X X X X M	Flange »S«: 0025...2540 mm Flange »C«, »D«, »M«, »T«: 0025...5080 mm
Stroke length (mm)	Ordering steps
25... 500 mm	5 mm
500... 750 mm	10 mm
750... 1000 mm	25 mm
1000... 2500 mm	50 mm
2500... 5080 mm	100 mm
X X X X U	Flange »S«: 001.0...100.0 in. Flange »C«, »D«, »M«, »T«: 001.0...200.0 in.
Stroke length (in.)	Ordering steps
1 ... 20 in.	0.2 in.
20... 30 in.	0.4 in.
30... 40 in.	1.0 in.
40... 100 in.	2.0 in.
100... 200 in.	4.0 in.
Non standard stroke lengths are available; must be encoded in 5 mm/0.1 in. increments	

e	Number of magnets
0 X	01...02 Position(s) (1...2 magnet(s))

f	Connection type
Connector	
D 3 4	M12 male connector (5 pin)
D 6 0	M16 male connector (6 pin)
Angled cable outlet	
E X X	XX m/ft. PVC cable (part no. 530 032) E01...E30 (1...30 m/3...99 ft.) See "Frequently ordered accessories" for cable specifications
G X X	XX m/ft. FEP cable (part no. 530 157) G01...G30 (1...30 m/3...99 ft.) See "Frequently ordered accessories" for cable specifications
L X X	XX m/ft. PUR cable (part no. 530 052) L01...L30 (1...30 m/3...99 ft.) (Note the temperature range of the cable!) See "Frequently ordered accessories" for cable specifications
U X X	XX m/ft. Silicone cable (part no. 530 176) U01...U30 (1...30 m/3...99 ft.) See "Frequently ordered accessories" for cable specifications
Straight cable outlet	
H X X	XX m/ft. PUR cable (part no. 530 052) H01...H30 (1...30 m/3...99 ft.) (Note the temperature range of the cable!) See "Frequently ordered accessories" for cable specifications
R X X	XX m/ft. PVC cable (part no. 530 032) R01...R30 (1...30 m/3...99 ft.) See "Frequently ordered accessories" for cable specifications
T X X	XX m/ft. FEP cable (part no. 530 112) T01...T30 (1...30 m/3...99 ft.) See "Frequently ordered accessories" for cable specifications
Encode in meters if using metric stroke length. Encode in feet if using US customary stroke length.	



g	System
1	Standard

h	Output
A	Current
V	Voltage

i	Function
1	Position (1 or 2 magnets/outputs)
2	Position and speed (1 magnet and 2 outputs)
3	Position and velocity (1 magnet and 2 outputs)
4	Position and reverse position (1 magnet and 2 outputs)
5	Position and temperature inside the sensor electronics housing (1 magnet and 2 outputs)
6	Differential (2 magnets and 1 output)

j	Options
0	Standard
3	Over range output mode

k	Output range
0	0...10 VDC or 4...20 mA
1	10...0 VDC or 20...4 mA
2	-10...+10 VDC or 0...20 mA
3	+10...-10 VDC or 20...0 mA
V	0...10 VDC for position, -10...+10 VDC for velocity

l	Max speed or velocity value
(optional: use when i "Function" is 2 or 3)	
<input type="checkbox"/>	For metric stroke lengths encode speed or velocity in m/s for the values 0.01 to 9.99 m/s (001...999)
<input type="checkbox"/>	For US customary stroke lengths encode speed or velocity in inches/s for the values 1 to 400 in./s (001...400)
Use the codes (00E) for 0.025 m/s, and (A00) for 10.0 m/s to provide backwards compatibility for these predecessor models of the R-Series.	

NOTICE

- Specify the number of magnets for your application and order the magnets separately.
- The number of magnets is limited by the stroke length. The minimum allowed distance between magnets (i.e. front face of one to the front face of the next one) is 75 mm (3 in.).
- Use magnets of the same type for multi-position measurement.

DELIVERY



RDV-C/-D/-M/-T:
Sensor, O-ring

Accessories have to be ordered separately.

RDV-S:
Sensor, O-ring, back-up ring

Manuals, Software & 3D Models available at:
www.temposonics.com

GLOSSARY

A

Analog output

For a sensor with analog output, the measured value is output as an analog voltage signal or current signal.

D

Differential

For differential measurement, the distance between the two position magnets is output as a value.

(→ Multi-position measurement)

M

Max speed or velocity value

For speed or velocity, the output value generated is scaled based on the maximum speed or velocity value indicated in the order code.

Measuring direction

- Forward: Values increasing from sensor electronics housing to rod end/profile end
- Reverse: Values decreasing from sensor electronics housing to rod end/profile end

Multi-position measurement

During the measurement cycle, the positions of every magnet on the sensor are simultaneously reported. The velocity or speed are continuously calculated based on these changing position values as the magnets are moved.

O

Over range output mode

When enabled this mode allows the position output values to continue to increase or decrease when the magnet travels beyond the active stroke range.

R

Resolution

The sensor precisely measures time to provide the position measurement. For the analog output the measured time value is converted into an analog voltage signal or current signal using a high-performance **D**igital to **A**nalog **C**onverter (DAC) having 16 bits of resolution.

S

Speed

The output value for speed indicates how fast the position magnet is being moved, independent of the measuring direction. (→ Velocity)

T

Temperature inside the sensor electronics housing

The temperature inside the sensor electronics housing is reported as an analog voltage signal or current signal. For each output range, the 0 % output value has the factory default setpoint at -40 °C, and the 100 % output value has the default setpoint at +100 °C.

Note: a dedicated temperature chip is used for the output signal and its values may vary from those reported on the TempoLink® application screen.

V

Velocity

The output value for velocity indicates how fast the position magnet is being moved, and in which direction. (→ Speed)

UNITED STATES
Temposonics, LLC
Americas & APAC Region
3001 Sheldon Drive
Cary, N.C. 27513
Phone: +1 919 677-0100
E-mail: info.us@temposonics.com

GERMANY
Temposonics
GmbH & Co. KG
EMEA Region & India
Auf dem Schüffel 9
58513 Lüdenscheid
Phone: +49 2351 9587-0
E-mail: info.de@temposonics.com

ITALY
Branch Office
Phone: +39 030 988 3819
E-mail: info.it@temposonics.com

FRANCE
Branch Office
Phone: +33 6 14 060 728
E-mail: info.fr@temposonics.com

UK
Branch Office
Phone: +44 79 21 83 05 86
E-mail: info.uk@temposonics.com

SCANDINAVIA
Branch Office
Phone: +46 70 29 91 281
E-mail: info.sca@temposonics.com

CHINA
Branch Office
Phone: +86 21 2415 1000 / 2415 1001
E-mail: info.cn@temposonics.com

JAPAN
Branch Office
Phone: +81 3 6416 1063
E-mail: info.jp@temposonics.com

Document Part Number:
552135 Revision A (EN) 11/2022



temposonics.com