

Designed specifically for performing tests in accordance with ASTM D5656, Standard Test Method for Thick-Adherend Metal Lap-Shear Joints for Determination of the Stress-Strain Behavior of Adhesives in Shear by Tension Loading. The deformation is measured on opposite sides of the test specimen and the output is an average of the two readings.



Model 4013 lap shear extensometer

The Model 4013 extensometer meets the requirements of ASTM D5656 for measuring the strain properties of an adhesive in shear. It uses different contact point spacing compared to the extensometer shown in D5656. This makes it much easier to mount and eliminates the slippage problems associated with the design shown in the ASTM standard. The Model 4013 is available with all of Epsilon's temperature configurations. It has a 3.0 mm (0.12 inches) full scale measuring range. The conical point contacts included with the extensometer are made from tungsten carbide.

The Model 4013 extensometers are strain gaged devices, making them compatible with any electronics designed for strain gaged transducers. Most often they are connected to a test machine controller. The signal conditioning electronics for the extensometer is typically included with the test machine controller or may often be added. In this case the extensometer is shipped with the proper connector and wiring to plug directly into the electronics. For systems lacking the required electronics, Epsilon can provide a variety of solutions, allowing the extensometer output to be connected to data acquisition boards, chart recorders or other equipment.

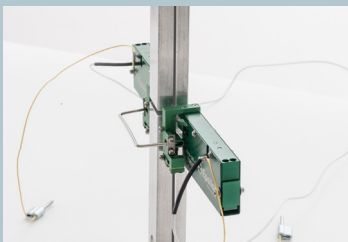

Side view of the Model 4013 lap shear extensometer with zero pins removed



Close-up of the 3 conical contact points used by the Model 4013 extensometer

Features

- High accuracy - strain is measured on opposite sides of the specimen and output as an average (single connector), or optionally as two independent readings (two connectors).
- Meets the requirements of ASTM D5656.
- Easy mounting, attaches with an integral spring.
- Includes the Epsilon Shunt Calibration System for on-site electrical calibration.
- Rugged, dual flexure design for improved performance.
- Full bridge, 350 ohm strain gaged design for compatibility with nearly any test system.
- Includes high quality foam lined case.

SPECIFICATIONS

Excitation: 5 to 10 VDC recommended, 12 VDC or VAC max.

Output: 2 to 4 mV/V nominal, depending on model

Linearity: ≤0.20% of full scale measuring range, depending on model

Temperature Range: Standard (-ST) is -40 °C to +100 °C (-40 °F to 210 °F)
Optional (-LHT) is -270 °C to +200 °C (-454 °F to 400 °F)

Cable: Integral, ultra-flexible cable, 2.5 m (8 ft) standard

OPTIONS

Option for independent left and right measurement outputs (two connectors - requires two strain channels)
Connectors to interface to nearly any brand of test equipment



ORDERING INFORMATION

Model 4013 Available Versions: ANY combination of measuring range and temperature range listed below is available, except as noted.

Measuring Range	
METRIC	
-005M	0.5 mm
-010M	1.0 mm
-030M	3.0 mm
U.S.A.	
-025T	0.025"
-050T	0.050"
-125T	0.125"

Model Number 4013- _____ - _____

Temperature Range	
-LT	-270 °C to 100 °C (-454 °F to 210 °F)
-ST	-40 °C to 100 °C (-40 °F to 210 °F)
-HT1	-40 °C to 150 °C (-40 °F to 300 °F)
-HT2	-40 °C to 200 °C (-40 °F to 400 °F)
-LHT	-270 °C to 200 °C (-454 °F to 400 °F)

Example: 4013-005M-ST: 0.5 mm measuring range, standard temperature range (-40 °C to 100 °C)

Visit our website at www.epsilontech.com
Contact us for your special testing requirements.

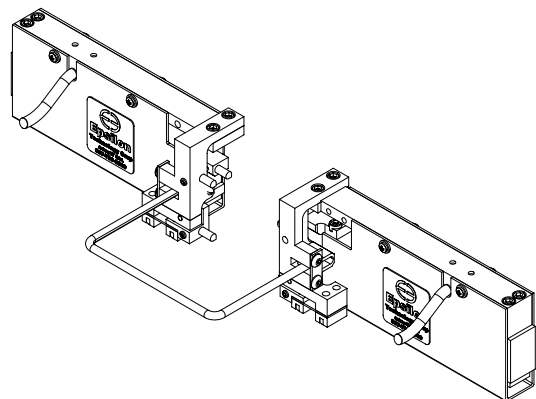

MODEL 4013 EXAMPLE