



T14/T20/T40 EDDY CURRENT PROBES

- contactless distance measurement due to non-contact measuring principle for measuring ranges up to 45 mm
- highest precision in difficult industrial environments
- resistant to contamination, high temperatures and pressure
- high temperature stability
- robust design



TECHNICAL DATA – SENSORS

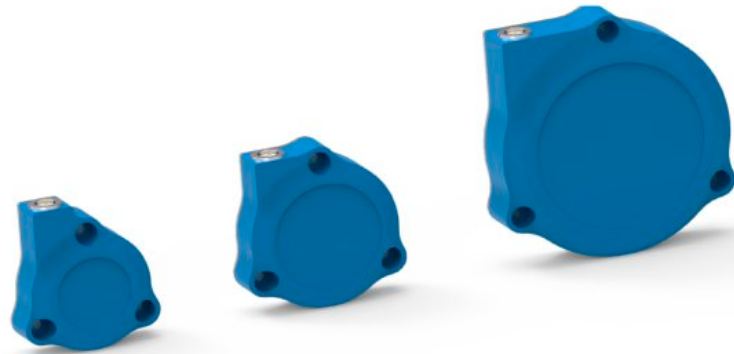

SENSOR	T14	T20	T40
measurement range [mm]	0...14	0...20	0...40
measurement range extended [mm]*	15	24	45
housing size	Ø43/54	Ø52/64	Ø82/94
offset gap (blind range)		~ 0.01 mm	
linearity		±0.15% of range	
resolution reg. corner frequency [% FS]**			
10 Hz	0.01	0.006	0.007
100 Hz	0.015	0.008	0.008
1 kHz	0.035	0.021	0.014
10 kHz	0.061	0.040	0.033
35 kHz	0.088	0.078	0.064
temperature range sensor		-40...150 °C	
temperature coefficient sensor		dependent on distance	
sensor cable PTFE-COAX		Ø2,5 mm (max. 2.7 mm), extension cable with LEMO connector required	
cable length		standard length 3 m / 6 m / 9 m / 12 m / 15 m	
min. bend radius static/dynamic		15/37 mm	
temperature range cable		-55...+200 °C	
connection		multipole female LEMO connector	
protection class		IP68	
vibration		20 g, DIN EN 60068-2-6	
shock		100 g / 6 ms, DIN EN 60068-2-27	
check resistance [Ω]	8	9	12
housing material		PPS/PPSU (sensor housing), stainless steel 1.4305 (back cover)	

* Linearity and resolution are not valid for extended measurement ranges

** 98.5% confidence interval (confidence limit), middle of range as % of range. Resolution dependent on the distance.

PLEASE NOTE:

Further information about the eddy current measuring principle, the eddy current software eddyMOTION, technical data, drawings and pin assignment of the TX electronics as well as further accessories can be found in the eddylab data sheet for the eddy current sensor TX (https://www.eddylab.com/eddylab-en/products/eddy-current-probes/Eddy_current_TX.pdf)

TECHNICAL DRAWINGS – SENSORS

■ T14

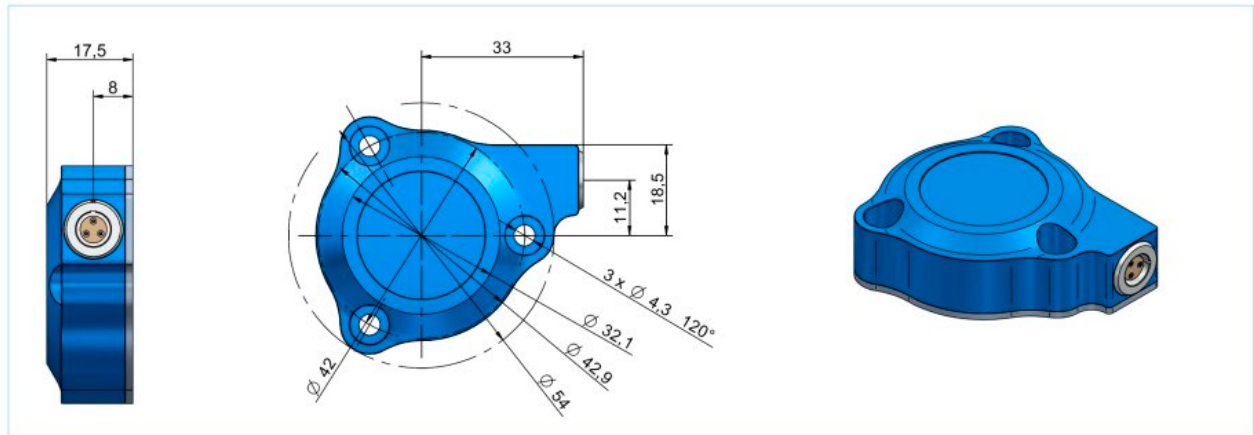

■ T20

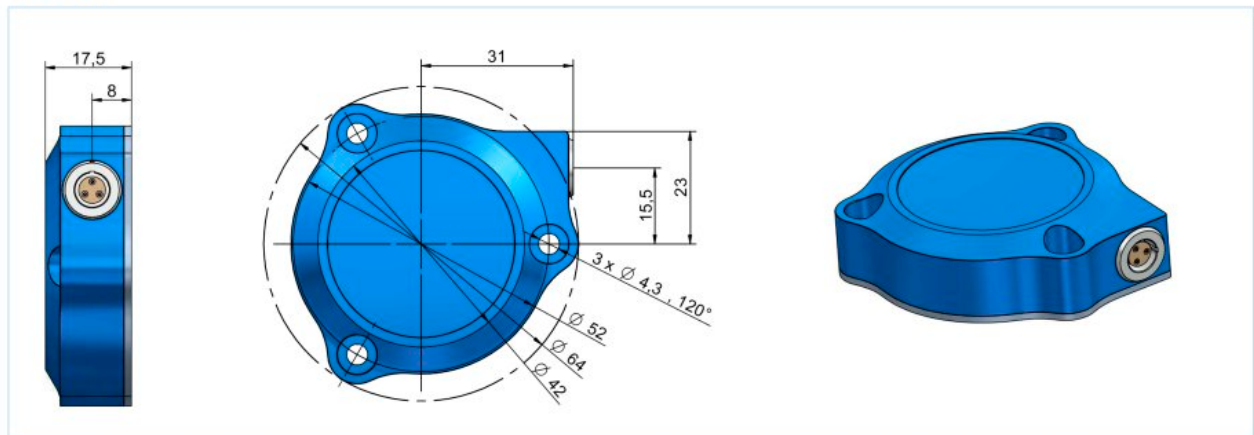

■ T40

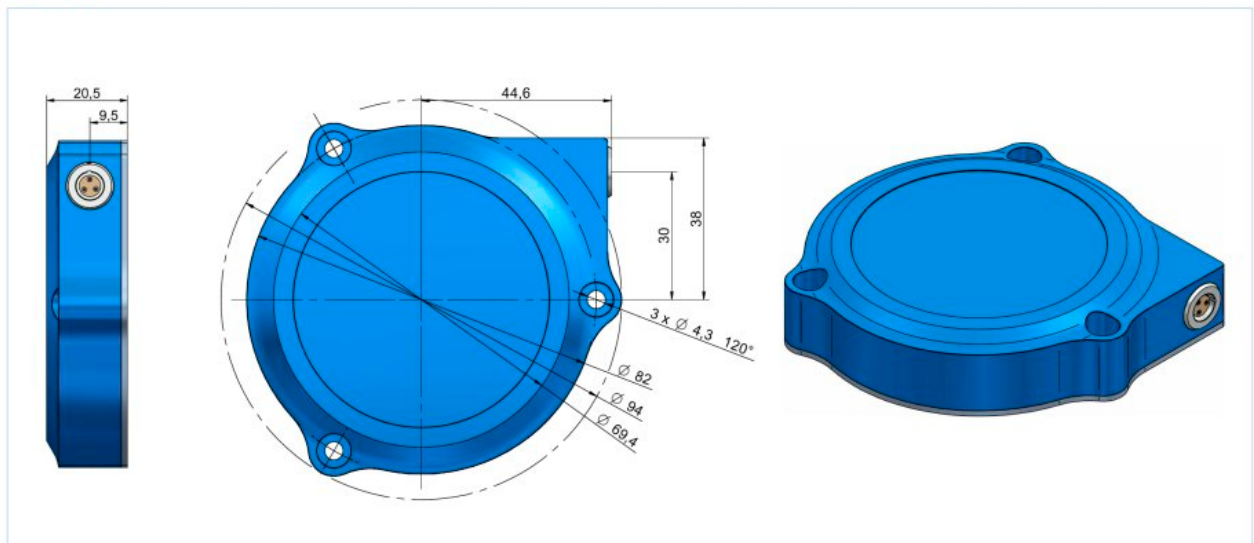

CABLE CONFIGURATION

The sensors are supplied with a multipole female LEMO connector as standard. For connection to the TX-Driver a cable with BNC connector is required. Optionally the cable are equipped with a SMB connector. The SMB connection is performed as BNC/SMB adaptor.

Please note:

The connector housing has an outer diameter of 6.5 mm. This facilitates the installation in particular with narrow conditions. If the cable is durably affixed, it might be desirable only to remove the probe from the entire cable.

It is recommended to avoid unnecessary connections within the cable as it increases the probability of failure due to environmental influences such as wetness, dirt, aggressive media, massive vibration, or shock.

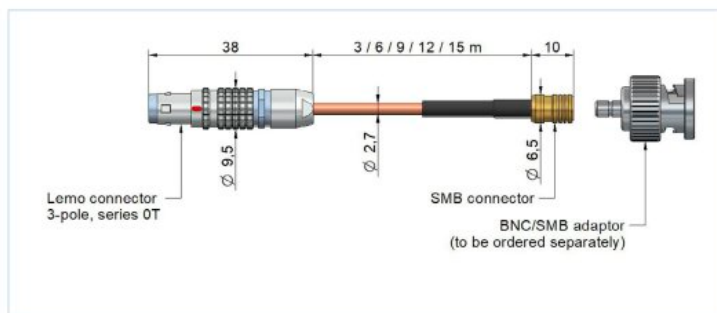
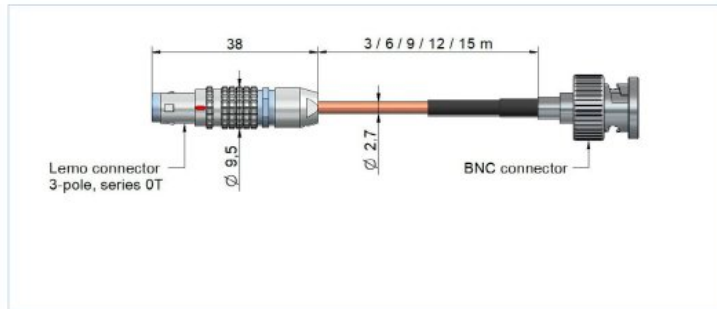

STANDARD VERSION

SENSOR WITH FEMALE LEMO CONNECTOR CONNECTION CABLE WITH BNC CONNECTOR 3/6/9/12/15M:

- LEMO.0T-KOAX-3M
- LEMO.0T-KOAX-6M
- LEMO.0T-KOAX-9M
- LEMO.0T-KOAX-12M
- LEMO.0T-KOAX-15M

OPTIONAL VERSION

CONNECTION CABLE WITH SMB CONNECTOR AND BNC/SMB ADAPTOR:

- LEMO.0T-KOAX-3M-SMB
- LEMO.0T-KOAX-6M-SMB
- LEMO.0T-KOAX-9M-SMB
- LEMO.0T-KOAX-12M-SMB
- LEMO.0T-KOAX-15M-SMB
- BNC/SMB (adaptor for connection to TX-Driver)

EDDY CURRENT BASIC MODULE TX

The processor based design admits linearities less than 0.1 % - which is an exceptional feature for this sensor technology. Remarkable performance allows highly dynamic measurements with 124 kSa/s. The TX-Driver is available as single- or dual-channel device. As standard, the device provides a USB and a CAN-bus Interface. The power supply is a galvanically isolated wide input from 10.5...36 (27) VDC.

All available sensor heads can be connected with the basic module TX.

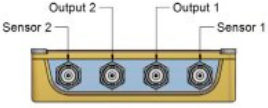

- **Probe and analogue output:**
Isolated output and high-speed signals via BNC connector. Selectable output signals 10 V, 5 V, ± 5 V, 0...20 mA, 4...20 mA.
- **Benefit 2-channel unit:**
2 different probes can be connected to one TX-driver.
- **Benefit 1-channel unit:**
Highest dynamic performance. The output sampling rate is 124 kSa/s.

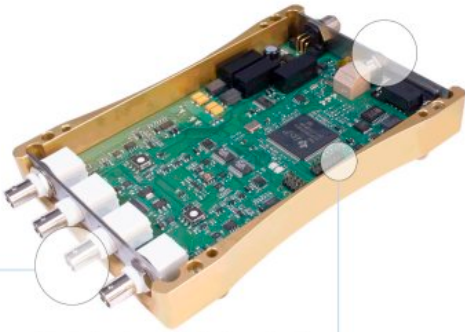
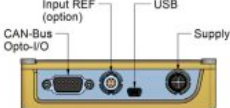

Illustration shows the 2-channel unit



- **Supply:**
Wide-Input-supply 10.5...36 (27) VDC, screwable M12 connector for shielded cables; galvanically isolated.
- **CAN-Bus:**
Data transfer via CAN bus for diverse systems with multi channel measurement.
- **USB connection:**
Interface to PC and data transfer. Usage of eddyMOTION software. Direct communication via USB protocol.
- **Reference input:**
Optional high-speed counter for linearisation- and rpm-function (eddyIMOTON reference).

Processor linearised signal conditioning

- linearisation and calibration with 50 points
- high dynamic performance with selectable digital filter
- high resolution and precision

CALIBRATION



THE FOLLOWING VARIANTS OF CALIBRATION ARE AVAILABLE:

- Factory calibration for one material including certificate.
- Factory calibration for three different materials. The materials are chosen with eddyMOTION lite/standard/reference including three certificates.
- Factory calibration including certificate plus customer based linearisation on-site with a digital gauge and eddylab reference (requires REF option for the TX-driver). The accuracy behaviour of an eddy current sensor can be proved and improved on-site with a digital gauge as reference.

All of our probes are tested and calibrated before shipping. The calibration is based on 50 positions. Every probe has a unique setup - therefore the probes may not be interchanged among different drivers.

The certificate of calibration contains the measured and reference data, the sensitivity, the target material and the linearity as a chart. The certificate of calibration is provided as standard - but it is also available subsequently.

TARGET-MATERIAL

Eddy current measurements depend on the target's conductivity and permittivity. The default material for factory calibration is steel of type 16MnCr5. Calibration is also possible with other conductive material such as aluminium, titanium, carbon fibre etc.

The following list shows available material for calibration. If you desire to use a different material we recommend to provide a probe (50x50 mm) for calibration.

MATERIALS TO CHOOSE FROM FOR CALIBRATION		
16MnCr5	1.2379	AlMgSi0,5
42CrMo4	1.2738	AlMg4,5Mn
St52	1.4301	AlMgCuPb
C45E	1.4305	95Mn28k

also eligible for calibration: zinc plate, titanium, carbon fiber

INSTALLATION

ELECTRICAL INSTALLATION

Choose a dry location, preferably with a stable temperature for the electrical installation (TX-Driver) such as electrical cabinets, terminal boxes, housing, etc. Connect the supply line, probe lines and output lines. Please ensure that all supply and signal lines are laid separately from energy-carrying lines such as supply and discharge lines from converters and drives, lines from ovens and synchronised appliances or generator lines, etc., in order to avoid malfunctions in the signal behaviour.

Please use shielded supply lines only and apply the shield to one side to avoid ground loops.

Please observe the correct assignment of the probes to the respective basic modules and channels. Each individual channel is aligned by the probe as a pair.

PROBE INSTALLATION

Firstly, install the probe at the relevant installation location. After you have installed the probe, lay the cable. Ensure that the cable is laid without dents and is not placed under stress. Secure excess probe cable as far away from temperature influences as possible, i.e., close to electronics. Never shorten the probe cable!

OBJECT SIZE AND THE EDDY CURRENT MEASUREMENT FIELD

The sensing electromagnetic field (illustrated in red) is emitted elliptically from the probe and is greater than the probe head in terms of its spatial expansion. For standard-calibrated probes a surface with a target diameter 2-3 times greater than the probe head diameter is necessary for measurement. If the object is too small, only a part of the measurement field enters the material, and the output signal becomes larger. If the diameter is too small, the object appears to be further away from the sensor. A similar effect takes place in the case of round objects.

However, if other conductive objects collide with the sensing electromagnetic field the output signal is reduced due to pre-attenuation. The actual object appears to be closer to the probe. If this signal alteration is not desired, we provide a customer-specific linearisation for such applications. In this case, the probe is calibrated within the pre-attenuating environment. The measuring system will fulfill the standard specification. The object (shape, material) is documented in the calibration document.

PRECAUTIONS



- **Never shorten the probe's coaxial cable. The probe, cable and electronic system form a coordinated oscillating circuit.**
- **Lay the cable so that it is protected and avoid running it along objects with sharp edges. A cable that has been squashed or damaged in another manner can tamper with the signal or render the probe unusable.**
- **Please note that the sensors have been aligned with the electronic system. The alignment can be found in the calibration record or on the label on the unit, identified by the serial number. Do not switch the channels.**
- **Avoid placing the cable under tensile or torsional stress.**
- **Protect the plug connections in the coaxial line against humidity and wetness.**
- **The sensors may not be used in strong radioactive environment (nuclear power plant).**

ORDER CODE

■ SENSOR

probe type
a - DSC - SR

a probe type
according to technical drawings, (e. g., T14, T20, T40)

■ CONNECTION CABLE

CONNECTION CABLE STANDARD

LEMO.0T-KOAX-3M
LEMO.0T-KOAX-6M
LEMO.0T-KOAX-9M
LEMO.0T-KOAX-12M
LEMO.0T-KOAX-15M

OPTIONAL CONNECTION CABLE + BNC/SMB-ADAPTOR

LEMO.0T-KOAX-3M-SMB
LEMO.0T-KOAX-6M-SMB
LEMO.0T-KOAX-9M-SMB
LEMO.0T-KOAX-12M-SMB
LEMO.0T-KOAX-15M-SMB

BNC/SMB-ADAPTOR

BNC/SMB



eddylab GmbH
Ludwig-Ganghofer-Str. 40, 83624 Otterfing

Telefon: +49 (0)8024 46772 - 0
FAX: +49 (0)8024 46772 - 100

E-mail: info@eddylab.de
Internet: www.eddylab.de



version: 23.02.2023