

- very rugged
- reliable
- operating temperature up to +140°C
- inductive power supply
- high accuracy
- simple installation



TELEMETRY SYSTEM

for strain gauge measurement on rotating parts

Telemetry System AXON J1DB

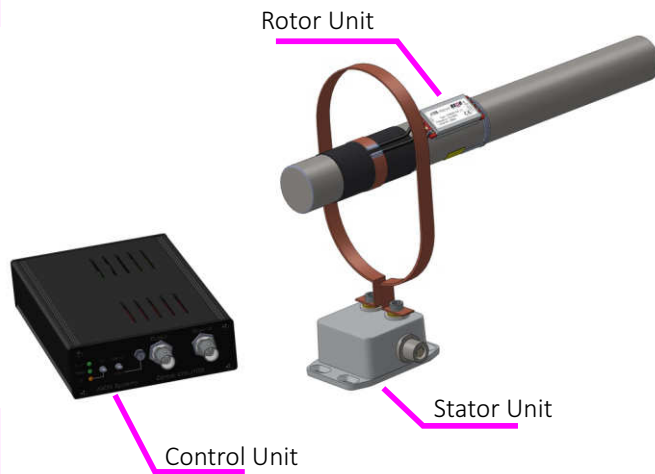

The telemetry system AXON J1DB is designed for transmitting strain gauge based measurement signals from rotating shafts under even hardest environments. During operation, a second transmission channel provides information about the inductively provided supply voltage on the rotating part of the system. The quality of the received digital data stream is also displayed via RSSI output. Through this valuable information, all important parameters for operation can be continuously monitored.



Rotor Unit:

Supplies the sensor with high-precision voltage, captures and processes the data from the strain gauge and transmits the fully digitised data stream contactless between the rotating shaft and the Stator Unit.



Control Unit:

The central control unit and data output of the telemetry system. Generates the inductive supply voltage for the rotor unit and reproduces the data measured on the shaft as a voltage signal. Inductive supply and RF data reception are monitored and always controlled during operation to ensure the best possible data transmission.

Stator Unit:

Produces the dynamic inductive field which supplies power to the Rotor Unit on the rotating shaft. Simultaneously it receives the digital data stream from the shaft. Distances up to 70mm between rotor and stator antenna can be realized. Axial and radial relative movements between stator and rotor are covered in an range of several centimeters⁽¹⁾.



(1) Depending on application

Funcional Principle

Telemetry System AXON J1DB

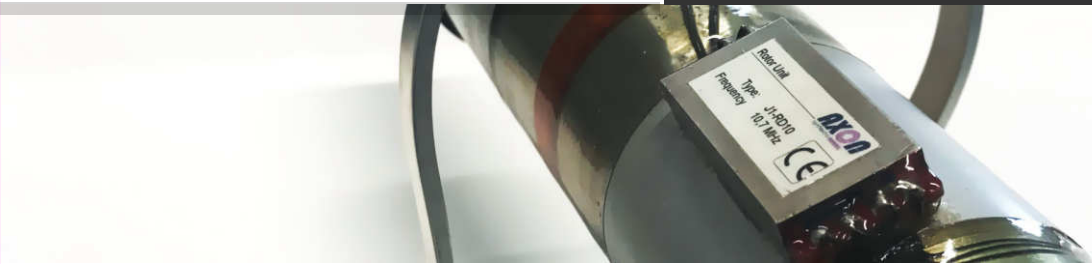
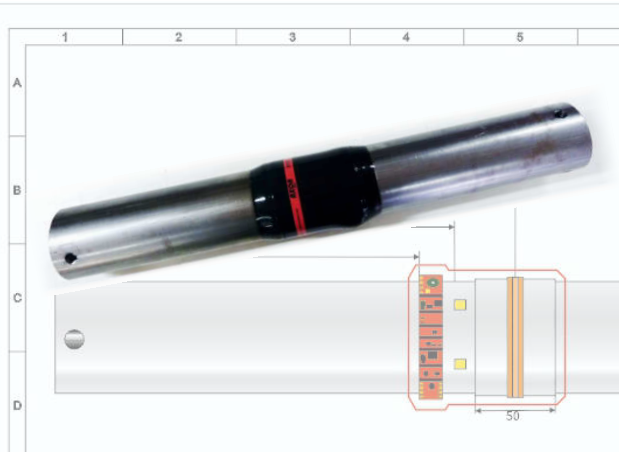

The ideal system for torque measurements

The J1DB telemetry system is the perfect foundation for highly professional torque measurement shafts that deliver stable and highly accurate measurement data, even under the toughest conditions. Whether in vehicle testing or on the test bench- AXON telemetry systems standing for reliable measurement results under a wide variety of applications.

The highly effective inductive power supply of the rotating components allows an uninterrupted use even under harsh conditions.

Even in oil, a stable power- and data transmission is ensured.

The distance between the stator and rotor antenna can easily vary between 1 and 70mm⁽¹⁾.

The intelligent inductive power transmission IPT continuously optimizes the rotor supply voltage during operation.

In addition, the RSSI output⁽²⁾ of the Control Unit provides information about the quality of the received data stream.

1) Depending on application

2) Receive Signal Strength Indicator

Strain gauge based measurements on:

- Drive shafts
- Prop shafts
- Torque Flanges
- Rotating gearbox parts
- and many more



Telemetry System AXON J1DB

Control Unit J1DB-CC

All relevant data accessible on CAN bus

In addition to the measurement data, which is available with its own CAN ID and a baud rate of up to 1MBit / s, the system transmits many other useful data in a separate status ID, such as:

- existing data transmission yes/no
- rotor Vs (level of inductive power supply on rotor)
- device name (freely configurable)
- serial number Control Unit
- serial number currently sending Rotor Unit
- calibration factor for measurement data output in Nm
- offset correction
- channel sample rate

To keep the system quickly accessible and fully flexible, most important values are also available as an analogue voltage signal:

- measurement values
- rotor Vs (level of inductive power supply on rotor)
- RSSI (received signal strength indication)

Software configured system settings can be conveniently exported as a .dbc file.



Inductive Power Supply 4.0:

Our new innovative Control Unit features the most efficient inductive power supply:

The active controlled inductive power supply increases the power where necessary but also decreases power when possible. Thus, power consumption of the entire telemetry system can be decreased by more than 60% for many applications.

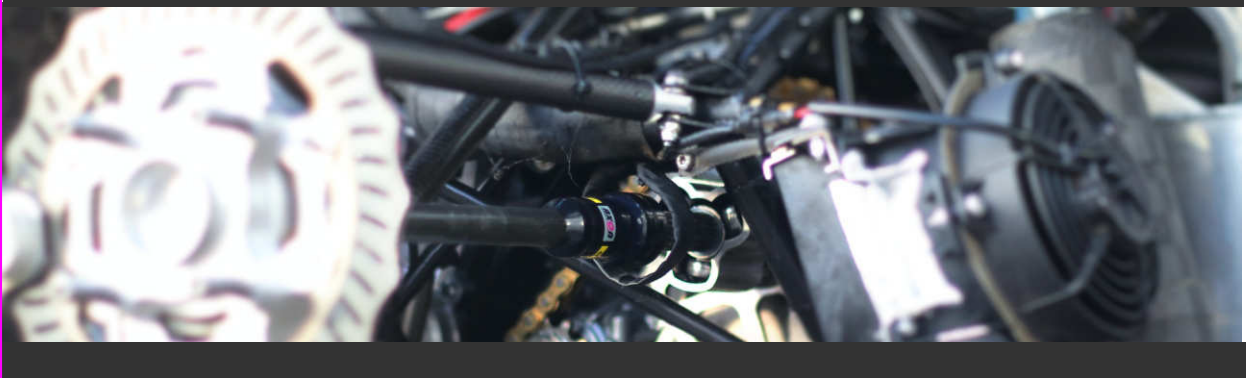
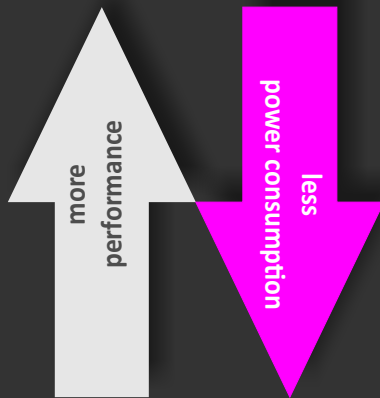

Telemetry System AXON J1DB

Rotor Units

Specifications

Chip Rotor



Flex Rotor



Head Rotor



Type	J1DB-RD13	J1DB-RF13	J1DB-RR13
Signal conditioning Ch1	1 x Strain gaug full bridge		
Signal conditioning Ch2	internal measurement of inductive power supply		
Power supply	inductively od battery		
Modulation	PCM (digital)		
ADC	16 bit		
Measurement range	0,1 - 500 mV/V adjustable		
Carrier frequency (standard)	13,6 MHz		
Carrier frequency (optional)	12,6 MHz, 14,6 MHz, 15,6 MHz		
Betriebstemperaturbereich	-40°C +105°C		
Temperature range option T	-40°C +125°C		
Temperature range option H	-40°C +140°C		
minimum bending radius	-	14 mm	-
Housing	Aluminium	without housing; flexible pcb board	without housing; cylindric design
Degree of protection	IP67 if the solder contacts are covered accordingly	IP10, electronics painted, cover after application with RTV silicone	IP10, electronics painted, cover after application with RTV silicone
Dimensions	45 x 19 x 7 mm	98 x 15 x 3,9 mm	Ø19mm x 12mm
Weight	10 grams	4,5 grams	3,5 grams
Conformity	CE		

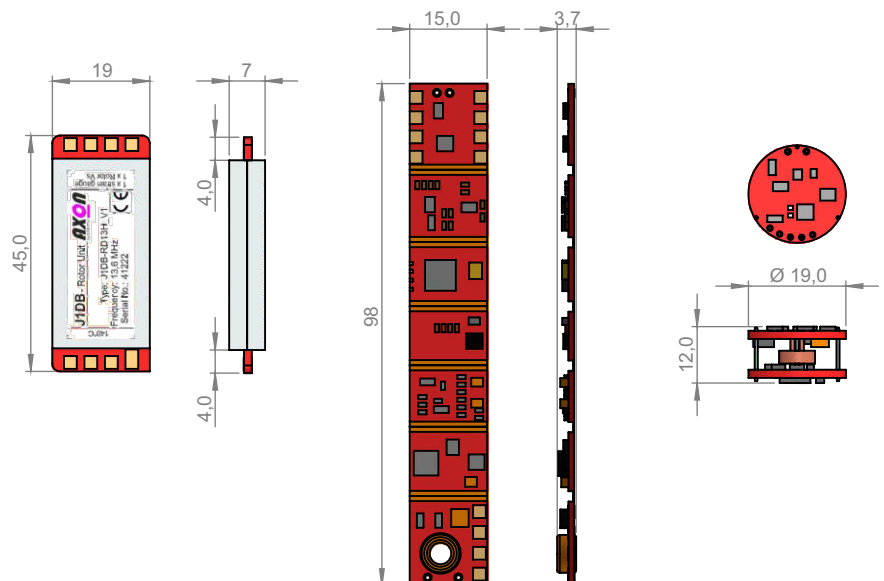

Alle Angaben in mm, Toleranz ±0,5mm

Telemetry System AXON J1DB

Stator Units

Standard Ringstator



Ringstator for high EMC loaded environments



designed for
e-Mobility
and applications working
under high EMC load

Type	JXD-SR70	JXD-SR70T	JXD-SR70E	JXD-SR70TE
Type of transmission	inductively with conductor loop (transmission coil)		inductively with conductor loop (transmission coil),	
Transmission coil	copper free shapeable Ø 40 500mm*		EMC-stator coil JX-ECE02 Ø 40 500mm*	
Transmission distance	0 70 mm ⁽¹⁾			
RF-Reception	wideband (10 MHz 30 MHz)			
Housing	Aluminium			
Connections	Fischer 4-pole, IP68			
Operating temperature	-40°C +105°C	-40°C +125°C	-40°C +105°C	-40°C +125°C
Cable length Stator - Control Unit	5m; optional 7m, 8m, 10m, 30m, 50m			
Weight	187 grams		189 grams	
Degree of protection	IP68			
Conformity	CE			

(1) Depending on application

*) diameters 500mm to 2 meters available as option

Recommended accessories

Copper band for stator ring of JX(D)-SR70(TP)

Free shapeable transmission coil for Stator Units JX(D)-SR70(T)E with additional EMC-terminal. Length 1m, shortenable

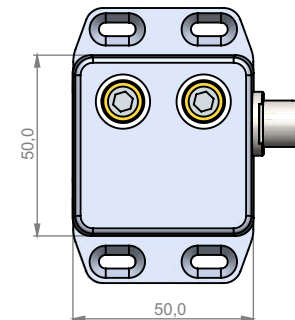
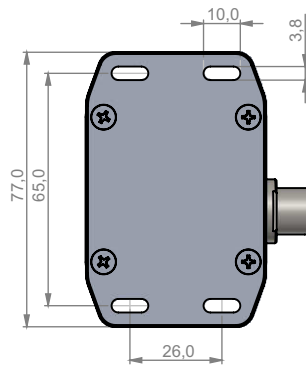
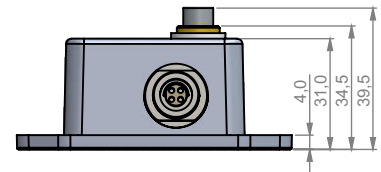
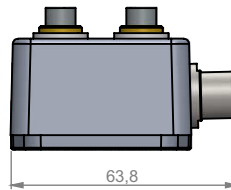

all dimensions in mm, tolerances ±0,5mm

Specifications

Telemetry System
AXON J1DB

Stator Units

Inductiv-Stator without transmission coil

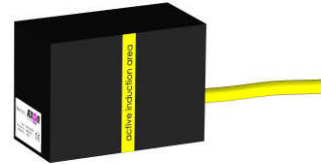

Specifications

Typ	JXD-SE60	JXD-SE60T
Type of transmission	inductive as Pick-Up	
RF-Reception	wideband (10 MHz 30 MHz)	
Housing	PTFE	
Transmission distance	0 60 mm ⁽¹⁾	
Dimensions (without cable)	70 x 50 x 35 mm	
Operating temperature	-40°C +105°C	-40°C +125°C
Cable length Stator - Control Unit	5m; optional 7m, 8m, 10m, 30m, 50m any cable length up to 200m on request	
Weight	220 grams	
Degree of protection	IP68	
Conformity	CE	

(1) Depending on application

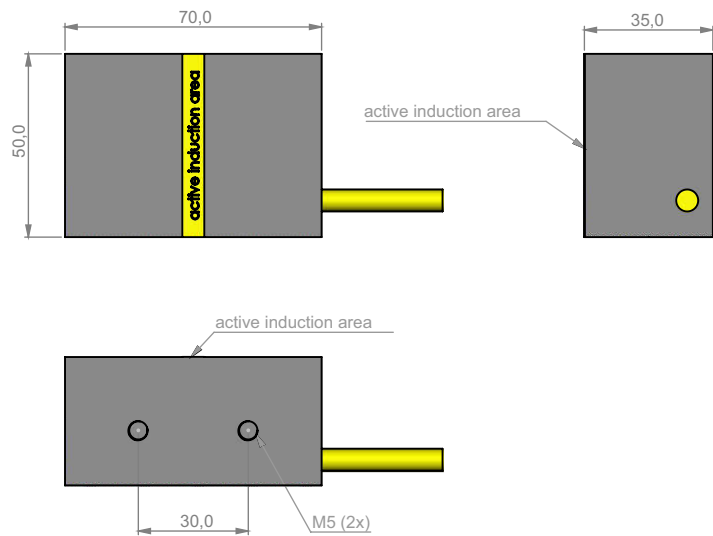

dimensions in mm, tolerances ±0,5mm

Telemetry System AXON J1DB

Control Unit

Controller CC / CAN
with analogue- and CAN-Bus output



Controller CE
with analogue output



Specifications

Typ	J1DB-CC13-10	J1DB-CC13-05	J1DB-CE13-10	J1DB-CE13-05
Dimension	187 x 105 x 54mm (incl. connectors)		205 x 105 x 35mm (incl. connectors)	
Weight	740 grams		580 grams	
Supply Voltage	9 - 36 VDC		9 - 36 VDC	
Power consumption, typically	12 VA		20 VA	
Hardware filter analogue output	1000 Hz (-3dB)		1000 Hz (-3dB)	500 Hz (-3dB)
Signal output Rotor Vs ⁽¹⁾	Phoenix 4-pol, 0-10V, factor 3:1		BNC, 0-10V, factor 3:1	
RSSI-Output ⁽²⁾	Phoenix 4-pol, 0-4,5V			
Baud rate	1 MBit/s	500kBit/s		
Channel sampling rate	50 - 1550 Hz, selectable in 50Hz-steps			
Signal outputs analog	Strain gauge measurement signal, Rotor Vs ⁽¹⁾ , RSSI ⁽²⁾			
Connection socket CAN	LEMO FGG.0B.305			
Signal output CAN-Bus	Measurement data strain gauge [selectively V or Nm ⁽³⁾], Rotor-Vs ⁽¹⁾ , Ready on/off, Control Unit serial number, Rotor Unit serial number, offset correction value, device name, channel sample rate			
Offset adjustment analogue			±0,5V, per poti	
Analogue output measurement signal			BNC, ±10V	
Carrier frequency (standard)			13,6 MHz	
Carrier frequency (optionally)			12,6 MHz, 14,6 MHz, 15,6 MHz	
Signal delay (analogue)			1,3 ms	
Wireless shunt calibration	released by push button on Control Unit			
Degree of protection	IP40			
Operating temperature	-20°C - +75°C			
Overvoltage protection	integrated			
Reverse polarity protection	integrated			
Conformity	CE			

(1) Supply voltage Rotor Unit

(2) Receive Signal Strength Indicator

(3) Calibration values for torque output can be stored on the device



The product is in compliance with the requirements of the following European directive:

199/5/EC Radio and Telecommunications Terminal Equipment (R&TTE)

2011/65/EU Restriction of the use of certain hazardous substances in electrical and electronic equipment (RoHS)

The compliance with the requirements of the European Directive was proved by the application of the following harmonized standards:

R&TTE: EN 300 330:2 V1.5.1
EN 301 489-1 V1.9.2
EN 301 489-3 V1.6.1
EN 50364:2010
EN 55011:2009+A1:2010
EN 60950-1:2006 + A11:2009 + A12:2011 + A1:2010 +A2:2013
RoHS: EN 50581:2012

The object of the declaration described above is in conformity with Directive 2011/65/EU of the European Parliament and of the Council of 8 June 2011 on the restriction of the use of certain hazardous substances in electrical and electronic equipment.

Telemetry System AXON J1DB

AXON „J“-series telemetry systems as an overview

- AXON J1
robust 1-channel telemetry system
for strain gauge measurements,
analogue transmission

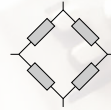

- AXON J1DB
digital 1-channel telemetry system
for strain gauge measurements with
monitoring of the rotor power supply



- AXON J2D
digital 2-channel telemetry system for
the simultaneous transmission of two
strain gauge signals

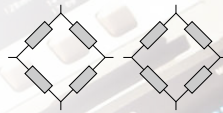

- AXON J2DT
digital 2-channel telemetry system for
the simultaneous transmission of one
strain gauge and one thermocouple signal



- AXON J1T
digital 1-channel telemetry system for
the transmission of one thermocouple
signal



- AXON J2T
digital 2-channel telemetry system for
the simultaneous transmission of two
thermocouple signals



- AXON J4T
digital 4-channel telemetry system for
the simultaneous transmission of four
thermocouple signals



- AXON J8T
digital 8-channel telemetry system for
the simultaneous transmission of eight
thermocouple signals



Applications

Telemetry System AXON J1DB

Shaft applications for torque- and temperature measurements
planned in detail - professionally built - delivered quickly

Another focus of AXON is the production of customized torque- and temperature measurement installations on shafts, flanges, and many other rotating components. Careful planning includes the preparation of release drawings, which allow the user to check all dimensions and details of the final installation.

The flexibility of the AXON telemetry systems enables the construction of installations that work even in the most difficult space conditions.

Sensors and electronics are sealed in multiple layers. A high-strength glass fiber composite protects the application from water, oil and mechanical damage. Thus, the maintenance-free applications are ideally suited for long-term driving tests.

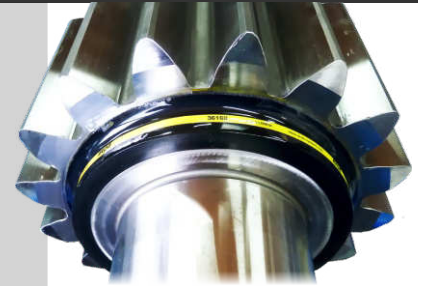

State-of-the-art technology
in a robust package

The flexible design options of
the AXON telemetry systems
allow countless application
variants.

- Telemetry
- Application
- Calibration

from one source
fast and reliable

**From development to
customized solutions -
all from one hand**

- Development and production
- Application of measurement shafts
- Strain gauge application and calibration

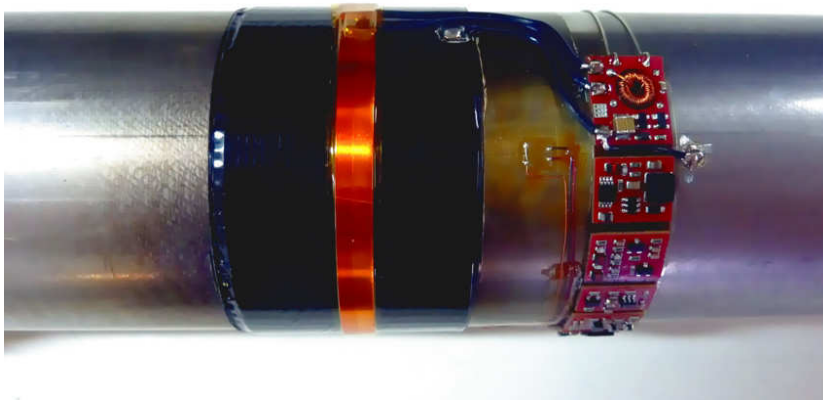
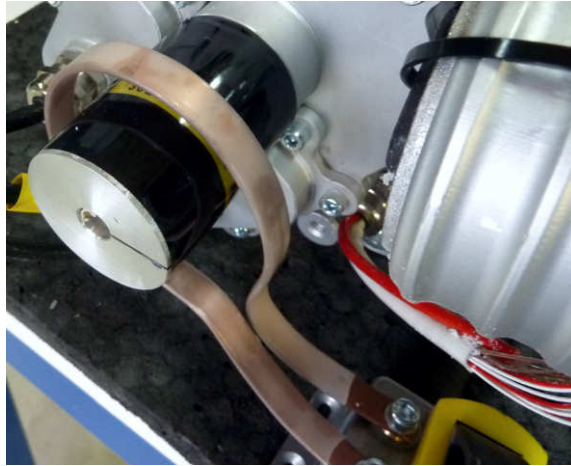

Whether by phone, e-mail or in person - our support is always available for questions about our systems - fast and easy!

Our experienced engineers and technicians will be happy to assist you in planning your measurement tasks - contact us!

Contents and illustrations of this datasheet have been elaborated to the best of our knowledge and with utmost diligence we reserve the right of error and technical modifications.